

- from its unperturbed position and the signal is thus lost in the base line. As r is increased, the magnitude of the dipolar field (r^{-3}) decreases and an increasingly large range of θ values yields an unperturbed EPR spectrum.
- (50) G. Palmer, "Methods for Determining Metal Ion Environments in Proteins", Elsevier North Holland Press, Amsterdam, in press.
- (51) D. A. Buckingham, M. J. Gunter, and L. N. Mander, *J. Am. Chem. Soc.*, **100**, 2899 (1978).
- (52) B. Bleaney and K. D. Bowers, *Proc. R. Soc. London, Ser. A*, **214**, 451 (1952).
- (53) S. Dessens, B. R. Welch, and L. J. Wilson, unpublished results.
- (54) M. G. Simmons and L. J. Wilson, *J. Chem. Soc., Chem. Commun.*, 634 (1978).
- (55) See, for example, M. Erscinska and D. F. Wilson, *Arch. Biochem.*, **188**, 1 (1978).
- (56) W. E. Blumberg and J. Peisach, *Biophys. J.*, **25**, 34a (1979).
- (57) W. Blumberg, The Japanese-American Seminar on Cytochrome Oxidase, Kobe, Japan, 1978, Paper 27.
- (58) C. A. Reed and J. T. Landrum, *FEBS Lett.*, in press.
- (59) P. D. W. Boyd and T. D. Smith, *Inorg. Chem.*, **10**, 2041 (1971); M. Nicholas, R. Mustaceich, and D. Jayne, *J. Am. Chem. Soc.*, **94**, 4518 (1972). For other FeOFe systems see D. H. O'Keefe, C. H. Barlow, W. S. Caughey, G. A. Smythe, W. H. Fuchsman, T. H. Moss, and H. R. Lilienthal, *Bioinorg. Chem.*, **5**, 125 (1975).
- (60) B. Chance, C. Saronio, and J. S. Leigh, *Proc. Natl. Acad. Sci. U.S.A.*, **72**, 1635 (1975).
- (61) See, for example, E. Bayer, D. Krauss, A. Roder, and D. Schretzmann, "Oxidases and Related Redox Systems", Vol. I, T. E. Kline, H. S. Mason, and M. Morrison, Eds., University Park Press, Baltimore, Md., 1973, Chapter II.
- (62) See, for example, J. V. Bannister, Ed., "Structure and Function of Haemocyanin", Springer-Verlag, West Berlin, 1977.
- (63) K. M. Kadish, G. Larson, D. Lexa, and M. Momenteau, *J. Am. Chem. Soc.*, **97**, 282 (1975).

Volatility and Molecular Structure of Neptunium(IV) Borohydride

Rodney H. Banks, Norman M. Edelstein,* Brock Spencer,¹ David H. Templeton,* and Allan Zalkin*

Contribution from the Materials and Molecular Research Division, Lawrence Berkeley Laboratory, and Department of Chemistry, University of California, Berkeley, California 94720. Received June 27, 1979

Abstract: The structure of $\text{Np}(\text{BH}_4)_4$ was determined by single-crystal X-ray diffraction methods at 130 K. The crystals are tetragonal, space group $P4_2/nmc$; $a = 8.559(9) \text{ \AA}$, $c = 6.017(9) \text{ \AA}$, $Z = 2$. $R = 0.114$ for 352 reflections (Mo $K\alpha$ radiation). The four borohydride ions are disposed tetrahedrally about the Np with Np-B distances of 2.46 (3) \AA . The boron atoms are connected to the Np atom with triple hydrogen bridge bonds similar to the terminal borohydrides in uranium borohydride. Hydrogen atoms were observed in the Fourier maps and refined. This molecular structure is similar to that found for hafnium and zirconium borohydride, but the space group is different. The vapor pressure, 10 mmHg at 25°C, was measured in the range of -5 to 25 °C using a Bourdon gauge.

Introduction

The relationship between the physical properties and structures of metal borohydrides has been studied extensively since the first preparation of metal compounds containing the BH_4^- anion.² One property which has attracted attention is the high volatility exhibited by some of them.^{3,4} No univalent metal borohydride is volatile and only a few of the lighter bis- and trisborohydrides show volatility below room temperature.⁵ Tetravalent Th, Pa, and U form borohydrides of low volatility, while Zr, Hf, Np, and Pu give tetrakisborohydrides of greater volatility.

The crystal structures of these seven compounds fall into three types. Thorium,^{3a} protactinium,⁴ and uranium^{6,7} borohydrides show one structure type which has been studied by X-ray and neutron diffraction methods for $\text{U}(\text{BH}_4)_4$. The 14-coordinate uranium is surrounded by six BH_4^- groups, two of which are triply hydrogen bridge bonded to the metal with a U-B distance of 2.53 \AA . The other four borohydride groups are bonded to the uranium by double hydrogen bridges giving a longer U-B distance of 2.87 \AA . These four bridging BH_4^- units use their remaining two hydrogens to link adjacent U atoms in a polymeric structure of C_2 symmetry at uranium.

Neutron-diffraction results on $\text{Hf}(\text{BH}_4)_4$ ⁸ and an X-ray diffraction study on the isostructural $\text{Zr}(\text{BH}_4)_4$ ⁹ have shown that these molecules crystallize into a different structure type and are monomeric. The metal atom is bonded to four tetrahedrally arranged borohydride groups by triple hydrogen bridge bonds giving the molecule rigorous T_d symmetry. The coordination sphere around Zr or Hf consists of only 12 hydrogen atoms. The corresponding Zr-B and Hf-B distances are 2.34 (3) and 2.28 (1) \AA , respectively.^{8a,9}

The third type,⁴ displayed by $\text{Np}(\text{BH}_4)_4$ and $\text{Pu}(\text{BH}_4)_4$, is somewhat similar to that of zirconium and hafnium borohydrides and is discussed here in detail.

In order to put the volatility of the third structure type on a quantitative basis, vapor-pressure measurements of $\text{Np}(\text{BH}_4)_4$ were carried out as a function of temperature, yielding various thermodynamic quantities. An X-ray crystallographic investigation of $\text{Np}(\text{BH}_4)_4$ at 130 K was undertaken to determine its detailed molecular structure.

Experimental Section

Vapor-Pressure Measurement. ²³⁷Np(BH_4)₄ was prepared and purified as described previously.⁴ The extreme chemical reactivity of $\text{Np}(\text{BH}_4)_4$ precluded the use of a mercury manometer and only an all-glass-and-Teflon Bourdon gauge was found satisfactory for these measurements. The exposed surfaces of the gauge were passivated with the neptunium borohydride vapor prior to use to minimize a decomposition reaction which evolves hydrogen and diborane.⁴ Excess $\text{Np}(\text{BH}_4)_4$ was condensed into the passivated gauge and the gauge was pumped out at -78 °C. At various temperatures, the compound was allowed to vaporize and deflect a pointer, whose initial position was precisely determined by a cathetometer. Shortly after equilibrium was established, the pointer was nulled to its original position by pressurizing the outer chamber of the gauge with argon. The argon pressure, as measured by a standard pressure gauge, then equaled the vapor pressure of the $\text{Np}(\text{BH}_4)_4$. Care was taken to remove all traces of H_2 and B_2H_6 before and after each measurement. Vapor-pressure readings were taken at room temperature and below until the vapor pressure of the compound approached the sensitivity of the Bourdon gauge.

Crystal Preparation. A sample of the dark green liquid $\text{Np}(\text{BH}_4)_4$ was sealed into a 0.3 mm i.d. quartz capillary and stored in liquid nitrogen prior to use. The capillary was mounted on a Picker FACS-I

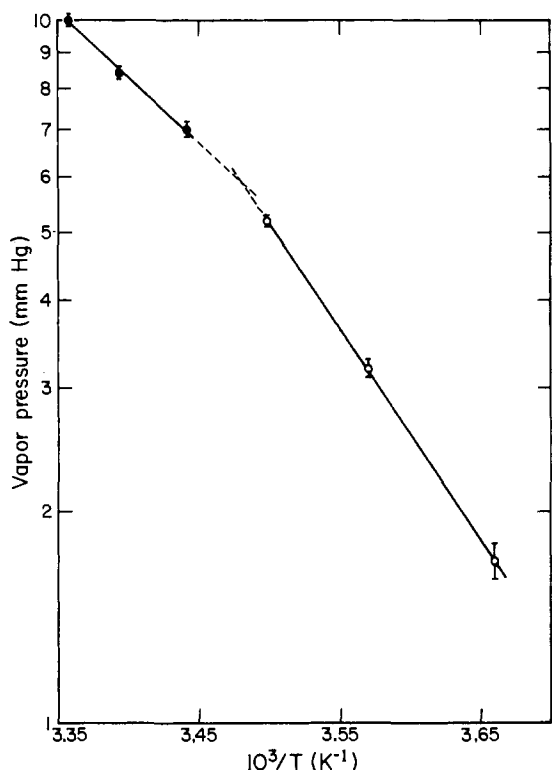

Figure 1. Vapor pressure vs. $10^3/T$ for $Np(BH_4)_4$. Open circles are for the solid and solid circles are for the liquid.

automated diffractometer equipped with a Syntex LT-1 temperature controller. Slow cooling through the melting point resulted in substantial supercooling followed by rapid freezing giving polycrystalline samples. Partial melting of the solid followed by slow refreezing provided a crystal suitable for structure determination.

X-Ray Diffraction. During unit-cell measurements and intensity data collection, the sample was maintained at 130 ± 5 K, as determined from prior calibration with a thermocouple in place of the capillary.

Unit cell parameters were obtained from carefully centered settings on the $K\alpha_1$ peaks of the (14,0,0) (0,14,0), and (0,0,10) reflections using graphite-monochromated Mo radiation ($\lambda(K\alpha_1) = 0.70930$ Å). Cell dimensions obtained before and after intensity data collection did not differ significantly and yielded the values $a = 8.559$ (9) and $c = 6.017$ (9) Å for the tetragonal unit cell; the density calculated for ^{237}Np and $Z = 2$ is 2.23 g cm^{-3} . The full width at half-height for ω scans of low-angle reflections before and after intensity data collection was typically 0.15° .

Intensity data were collected using the $\theta-2\theta$ scan technique to 68° in 2θ for positive h , k , and l with scans from 0.9° below $K\alpha_1$ to 0.9° above $K\alpha_2$ and with background counts of 4 s at each end of the scan. Two standards, measured every 100 reflections, showed a decrease in intensity of 17% during the course of data collection and the measured intensities of the 1000 reflections were corrected accordingly. Crystal faces were not clearly visible through the capillary so an absorption correction was not attempted (μ is 40 cm^{-1} and r is approximately 1×10^{-2} cm). The intensities were corrected for Lorentz and polarization effects. When the double data set was merged, the estimated standard deviation of the intensity of a reflection based on counting statistics was replaced by the scatter in measured intensities for 137 reflections (out of a total of 511 unique reflections) for which the scatter exceed four times the estimated standard deviations. The diffraction symmetry and systematically absent reflections were consistent with the space group $P4_2/nmc$.

With $Z = 2$, the Np atom must occupy a special position with $\bar{4}2m$ symmetry as noted from the earlier X-ray powder data⁴ which showed a body-centered pattern and intensities consistent with Np at the origin. The single-crystal experiment detected the weak non-body-centered reflections. The boron atom was initially placed 2.5 Å from the neptunium in an eightfold position on a mirror plane by analogy with the tetrahedral $Hf(BH_4)_4$ structure.⁸ After several cycles of

least-squares refinement with anisotropic thermal parameters for Np and an isotropic thermal parameter for B, inspection of the agreement between observed and calculated structure factors for the strongest reflections suggested that an extinction correction was appropriate. An empirical correction was applied where $F_{cor} = F_{obsd} (1 + 2.4 \times 10^{-7}I)$; F_{cor} and F_{obsd} are the corrected and observed structure factors and I is the observed intensity. Several additional cycles of least-squares refinement with anisotropic thermal parameters for both Np and B then converged with $R = \sum ||F_o| - |F_c|| / \sum |F_o| = 0.115$ for nine parameters and 352 data with $F^2 > \sigma(F^2)$.

A difference-Fourier map was calculated to see whether the hydrogen atoms could be located. Peaks with an electron density of approximately $1 e/\text{\AA}^3$ were found in positions expected for three bridging hydrogens and one terminal hydrogen as in the structure of $Hf(BH_4)_4$. An initial attempt to refine the hydrogen-atom positions would not converge and an attempt to refine a single isotropic thermal parameter converged to a negative value. Finally, with all hydrogens given the same fixed isotropic thermal parameter and with positional parameters allowed to shift only half of the indicated full-matrix value in each cycle, several additional cycles of least-squares refinement converged smoothly to the values given in Table II. The full-matrix least-squares program minimizes the function $\sum w |\Delta F|^2 / \sum w F_o^2$ where the assigned weights $w = [\sigma(F)]^{-2}$ were derived from $\sigma(F^2) = [S^2 + (pF^2)^2]^{1/2}$ where S^2 is the variance due to counting statistics and $p = 0.10$. The final R factors were 0.114 for 16 parameters and 352 data with $F^2 > \sigma(F^2)$ and 0.125 for all 511 data. The weighted $R_w = (\sum w (|F_o| - |F_c|)^2 / \sum w F_o^2)^{1/2}$ was 0.140 and the estimated standard deviation for an observation of unit weight was 2.15. The scattering factors used were those of Doyle and Turner¹⁰ for neutral boron, those of Stewart, Davidson, and Simpson¹¹ for hydrogen, and those from the International Tables¹² for Np^{4+} corrected for anomalous dispersion.

Results and Discussion

Neptunium borohydride is a volatile compound which moves about easily in a vacuum line and exerts 10 mmHg vapor pressure at room temperature. Using the data obtained from the vapor-pressure measurements, linear plots (Figure 1) were found for the equation $\log p_{mmHg} = -A/T + B$, where T is in degrees Kelvin, for liquid and for solid $Np(BH_4)_4$. Least-squares lines were fitted to the observed points and several thermodynamic quantities were calculated. These, along with some other properties of the metal tetrakisborohydrides, are listed in Table I.

The primary properties of these metal tetrakisborohydrides reflect the polymeric or monomeric nature of their solid-state structures. The polymeric thorium and uranium borohydrides are characterized by relatively low volatility, high melting points accompanied by decomposition, and low solubility in nonpolar and noncoordinating organic solvents such as n -pentane.¹³ The monomeric hafnium, zirconium, and neptunium borohydrides have much lower melting points and rapid decomposition does not occur upon melting. Their vapor pressures are about two orders of magnitude greater and they are soluble in n -pentane in all proportions. All of the metal tetrakisborohydrides are monomeric in the gaseous state. At room temperature $Pa(BH_4)_4$ is insoluble in $Zr(BH_4)_4$,¹⁴ but when the mixture is heated slightly above the sublimation temperature of $Pa(BH_4)_4$ the liquid turns deep yellow as the polymeric structure is disrupted and the Pa compound dissolves.

Despite the close similarity between the ionic radii of Np^{4+} and U^{4+} (the difference is 0.02 Å)¹⁵ as compared to those of Np^{4+} and Zr^{4+} (difference ~ 0.14 Å),¹⁵ the solid-state structure and physical properties of $Np(BH_4)_4$ resemble those of $Zr(BH_4)_4$. The gas-phase and low-temperature solid-state infrared and Raman spectra of $Np(BH_4)_4$ are almost identical (except for mass effects) with those of $Zr(BH_4)_4$, showing that the two structures are similar.⁴

The monomeric nature of solid $Np(BH_4)_4$ is established by the X-ray diffraction results. The molecule is shown in the ORTEP diagram (Figure 2) with the structural information listed in Tables III and IV. The neptunium atom is coordinated

Table I. Properties of Metal Tetrakisborohydrides^a

property	Th(BH ₄) ₄ ^b	U(BH ₄) ₄ ^c	Hf(BH ₄) ₄ ^b	Zr(BH ₄) ₄ ^b	Np(BH ₄) ₄
crystallographic space group	<i>P</i> 4 ₃ 2 ₁ 2 ^d	<i>P</i> 4 ₃ 2 ₁ 2 ^d	<i>P</i> 4̄3 <i>m</i> ^e	<i>P</i> 4̄3 <i>m</i> ^f	<i>P</i> 4 ₂ / <i>nmc</i>
solid-state structure	polymeric	polymeric	monomeric	monomeric	monomeric
mp, °C	203 ^g	126 ^g	29.0	28.7	14.2
bp, °C (extrap)			118	123	153
vapor pressure, mmHg/°C	0.05/130	0.19/30	14.9/25	15.0/25	10.0/25
heat of sublimation, kcal/mol	21	19.5	13.0	13.6	14.5
heat of vaporization, kcal/mol			9.6	9.3	8.5
heat of fusion, kcal/mol			3.4	4.3	6.0
liquid ^h A			2097	2039	1858
B			8.247	8.032	7.24
solid ^h A		4264.6	2844	2983	3168
B		13.354	10.719	10.919	11.80
solubility in <i>n</i> -pentane	insol	slight	high	high	high

^a The Pa and Pu compounds are not included in this table as most of the values for the listed properties are unknown. ^b Reference 3a. ^c J. J. Katz and E. Rabinowitch, "The Chemistry of Uranium", McGraw-Hill, New York, 1951. ^d Reference 6b. ^e Reference 8. ^f Reference 9. ^g With decomposition. ^h Log *p*(mmHg) = $-A/T + B$.

Table II. Positional and Thermal Parameters^a

atom	<i>x</i>	<i>y</i>	<i>z</i>	<i>B</i> ₁₁	<i>B</i> ₂₂	<i>B</i> ₃₃	<i>B</i> ₂₃
Np	0	0	0	1.94(5)	1.94(5)	2.07(6)	0
B	0	0.235(4)	0.233(5)	2.8(11)	3.0(12)	2.4(7)	-1.6(8)
H(1) ^b	0	0.33(3)	0.33(4)				
H(2) ^b	0	0.26(6)	0.05(4)				
H(3) ^b	0.10(3)	0.15(2)	0.24(6)				

^a The anisotropic temperature factor has the form $\exp(-0.25(B_{11}h^2a^{*2} + 2B_{12}hka^*b^* + \dots))$. Symmetry restraints of the thermal parameters of Np follow: $B_{11} = B_{22}$ and $B_{12} = B_{13} = B_{23} = 0$; for B $B_{12} = B_{13} = 0$. ^b The isotropic thermal parameter of the hydrogen atoms was constrained to a value of 3.0 Å² and its isotropic temperature factor has the form $\exp(-B \sin^2 \theta / \lambda^2)$.

Table III. Interatomic Distances (Å)

Np-4B	2.46(3)	H(1)-H(2)	1.8(5)
Np-H(2)	2.3(5)	H(1)-2H(3)	1.9(3)
Np-2H(3)	2.1(3)	H(2)-2H(3)	1.8(3)
B-H(1)	1.0(3)	H(3)-H(3)	1.8(4)
B-H(2)	1.1(2)	H(2)-2H(3) ^a	2.5(4)
B-2H(3)	1.2(2)	H(3)-H(3) ^a	2.5(4)

^a Distance to H(3) on an adjacent BH₄⁻ group.

Table IV. Angles (deg)

B-Np-B ^a	110.3(18)	H(3)-B-H(3)	100(22)
B-Np-B ^b	109.1(9)	Np-B-H(1)	179(16)
H(1)-B-H(2)	112(32)	Np-H(2)-B	85(26)
H(1)-B-H(3)	122(15)	Np-H(3)-B	93(16)
H(2)-B-H(3)	99(20)		

^a Symmetry operation 0, \bar{x} , *z*. ^b Symmetry operations *x*, 0, \bar{z} and \bar{x} , 0, \bar{z} .

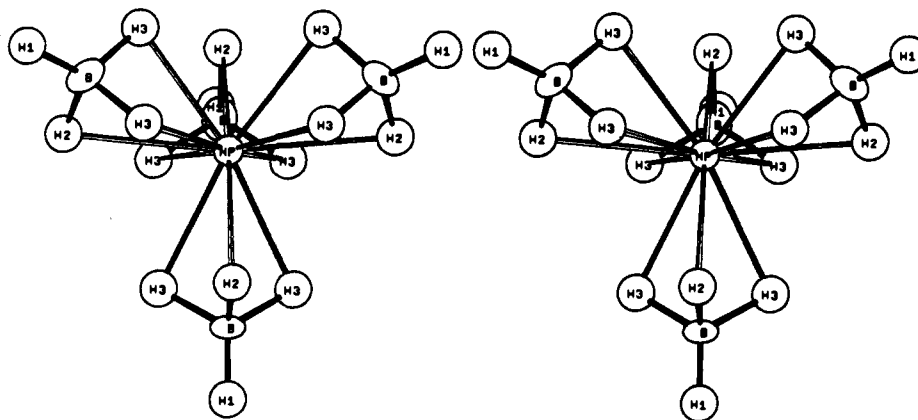
**Figure 2.** ORTEP stereoview of Np(BH₄)₄.

to four borohydrides through three bridging hydrogens each, with all B-Np-B angles being tetrahedral to within less than one estimated standard deviation, even though the crystallographic site symmetry for Np does not require regular tetrahedral geometry.

Bernstein et al.^{6a} observed that bridging borohydride groups give larger M-B distances than do the terminal ones in U(BH₄)₄. They suggested that an "ionic radius" of a terminal BH₄⁻ group be approximately 1.3 (1) Å and that of a bridging

BH₄ group be about 1.6 (1) Å. Using the value from Shannon and Prewitt¹⁵ for the radius of Np⁴⁺ and the Np-B distance of 2.46 Å, it is found that the BH₄⁻ radius is 1.34 Å. This is in good agreement with the values calculated for other triply bridged borohydride groups: U(BH₄)₄, 1.38,^{6a} 1.37 Å;¹⁶ Zr(BH₄)₄, 1.36,⁹ 1.33 Å;¹⁷ Hf(BH₄)₄, 1.31 Å.^{8a}

The borohydride group in Np(BH₄)₄ is tetrahedral within the estimated standard deviation with an average B-H bond length of 1.1 (2) Å. Neutron-diffraction investigations on

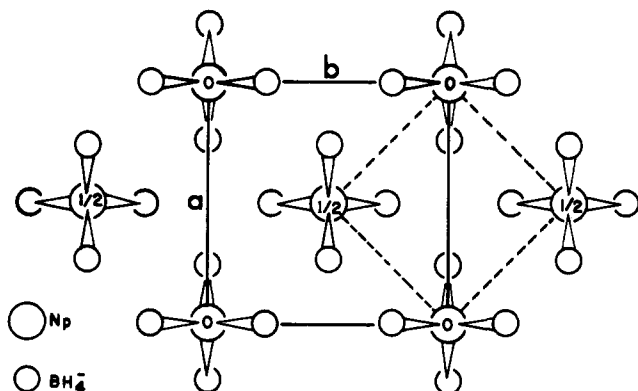

Figure 3. Schematic diagram of packing in $\text{Np}(\text{BH}_4)_4$. Solid line is the tetragonal $\text{Np}(\text{BH}_4)_4$ cell; the dotted line shows the cubic $\text{Zr}(\text{BH}_4)_4$ cell if the metal atoms were at $z = 0$. The H atoms are not shown.

"covalent" $\text{U}(\text{BH}_4)_4$ and $\text{Hf}(\text{BH}_4)_4$ revealed departures from T_d symmetry of the tridentate BH_4^- groups manifesting themselves as wider $\text{H}_t\text{-B-H}_b$ (113°) and smaller $\text{H}_b\text{-B-H}_b$ (106°) angles with respect to the tetrahedral angle, and as a shorter B-H_t (1.15 \AA) distance compared to the longer B-H_b (1.24 \AA) distances. Unfortunately the present X-ray diffraction results are not accurate enough to determine if these deviations from T_d symmetry are present in $\text{Np}(\text{BH}_4)_4$. A neutron structure determination of the "ionic" KBH_4 compound¹⁸ indicated that the BH_4^- group was symmetrical with all B-H bond lengths being $1.260(2) \text{ \AA}$ and the H-B-H angle of 109.5° . Whether the distortion of the BH_4^- groups in these compounds can be used to test for covalency^{5b} must await further neutron-diffraction results.

Although the hydrogen-atom positions have large estimated standard deviations and the inclusion of the hydrogen atoms in the refinement lowered the R factor a trivial amount, the hydrogen atoms refined to chemically reasonable positions. The terminal hydrogen atom is properly oriented away from the neptunium with a $\text{Np-B-H}(1)$ angle of $179(16)^\circ$. The 12 bridging hydrogen atoms around the neptunium are all 2.5 \AA away from it and form a coordination polyhedron in which each hydrogen atom is 1.8 \AA from two other hydrogen atoms in the same borohydride group and 2.5 \AA from two hydrogen atoms in adjacent borohydride groups. This polyhedron is similar to the cube-octahedron which describes the coordination in the cubic closest packing structure with six neighbors in a plane, three above, and three below. The inequality of the H-H distances corresponds to a tetrahedral distortion of this figure which changes the square faces into rectangles and the triangular faces into four larger ones and four smaller ones.

James et al.¹⁹ have suggested that $\text{Zr}(\text{BH}_4)_4$ may be of slightly lower T symmetry which is obtained by rotating all four BH_4^- groups from the staggered orientation by an angle of less than 60° about the Zr-B vector. They based their argument on an uncertain interpretation of an electron-diffraction study on gaseous $\text{Zr}(\text{BH}_4)_4$ ¹⁷ and on weak infrared transitions^{19b} which they assigned as fundamental modes. However, the staggered arrangement of bridging hydrogen

atoms offers the least amount of interhydrogen repulsion. Our work gives no evidence for symmetry lower than T_d for $\text{Np}(\text{BH}_4)_4$.

If the metal ion size is the determining factor in the number of bridging hydrogen atoms that can be accommodated in the coordination sphere of the metal in these borohydrides, this work pinpoints the transition from 14 to 12 coordination between U^{4+} and Np^{4+} , a difference of 0.02 \AA in ionic radius.

The solid-state molecular structure of $\text{Np}(\text{BH}_4)_4$ has the same basic geometry as $\text{Hf}(\text{BH}_4)_4$ and $\text{Zr}(\text{BH}_4)_4$ yet the crystal structures are different. The tetragonal unit cell (Figure 3) has one molecule at the origin and another (with inverted configuration) at the body center. If the second molecule were moved to $z = 0$ and inverted, this structure would be identical with that of the Zr and Hf compounds, apart from a deviation of about 0.6% from cubic lattice dimensions. The boron positions are hardly changed in this transformation, but the packing of their terminal hydrogen atoms is significantly different in the two structures.

Further work is underway on the spectroscopic properties of $\text{Np}(\text{BH}_4)_4$.

Acknowledgment. This work was supported by the Division of Nuclear Sciences, Office of Basic Energy Sciences, U.S. Department of Energy, under Contract No. W-7405-Eng-48.

Supplementary Material Available: Listing of structure factor amplitudes for $\text{Np}(\text{BH}_4)_4$ (2 pages). Ordering information is given on any current masthead page.

References and notes

- (1) On leave from the Chemistry Department, Beloit College, Beloit, Wis.
- (2) (a) Nibler, J. W. *J. Am. Chem. Soc.* **1972**, *94*, 3349. (b) Price, W. C. *J. Chem. Phys.* **1949**, *17*, 1044.
- (3) (a) Hoekstra, H. R.; Katz, J. J. *J. Am. Chem. Soc.* **1949**, *71*, 2488. (b) Schlesinger, H. I.; Brown, H. C. *Ibid.* **1953**, *75*, 219.
- (4) Banks, R. H.; Edelstein, N. M.; Rietz, R. R.; Templeton, D. H.; Zalkin, A. *J. Am. Chem. Soc.* **1978**, *100*, 1957.
- (5) (a) James B. D.; Wallbridge, M. G. H. *Prog. Inorg. Chem.* **1970**, *11*, 99. (b) Marks, T. J.; Kolb, J. R. *Chem. Rev.* **1977**, *77*, 263.
- (6) (a) Bernstein, E. R.; Hamilton, W. C.; Keiderling, T. A.; LaPlaca, S. J.; Lippard, S. J.; Mayerle, J. J. *Inorg. Chem.* **1972**, *11*, 3009. (b) Bernstein, E. R.; Keiderling, T. A.; Lippard, S. J.; Mayerle, J. J. *J. Am. Chem. Soc.* **1972**, *94*, 2552.
- (7) Recent work has shown that condensation of $\text{U}(\text{BH}_4)_4$ at -80°C results in a new solid phase: Charpin, P.; Marquet-Ellis, H.; Folcher, G., *J. Inorg. Nucl. Chem.* **1979**, *41*, 1143.
- (8) (a) Broach, R. S.; Chuang, I.-S.; Williams, J. M.; Marks, T. J., private communication, 1979. (b) Keiderling, T. A. Ph.D. Thesis, Princeton University, 1974.
- (9) Bird, P. H.; Churchill, M. R. *Chem. Commun.* **1967**, 403.
- (10) Doyle, P. A.; Turner, P. S. *Acta Crystallogr., Sect. A* **1968**, *24*, 390.
- (11) Stewart, R. F.; Davidson, E. R.; Simpson, W. T. *J. Chem. Phys.* **1965**, *42*, 3175.
- (12) Ibers, J. A.; Hamilton, W. C. "International Tables for X-ray Crystallography", Vol. IV; Kynoch Press: Birmingham, England, 1974; p 97.
- (13) For spectroscopic interest, they also have low solubility in $\text{Zr}(\text{BH}_4)_4$ and $\text{Hf}(\text{BH}_4)_4$.
- (14) Unpublished results in our laboratory.
- (15) Shannon, R. D.; Prewitt, C. T. *Acta Crystallogr., Sect. B* **1969**, *25*, 925.
- (16) Rietz, R. R.; Zalkin, A.; Templeton, D. H.; Edelstein, N. M.; Templeton, L. K. *Inorg. Chem.* **1978**, *17*, 653.
- (17) Plato, V.; Hedberg, K. *Inorg. Chem.* **1971**, *10*, 590.
- (18) Peterson, E. R. *Diss. Abstr.* **1965**, *25*, 5588.
- (19) (a) James, B. D.; Smith, B. E.; Shurvell, H. F. *J. Mol. Struct.* **1976**, *33*, 91. (b) Smith, B. E.; Shurvell, H. F.; James B. D. *J. Chem. Soc.* **1978**, 710.